

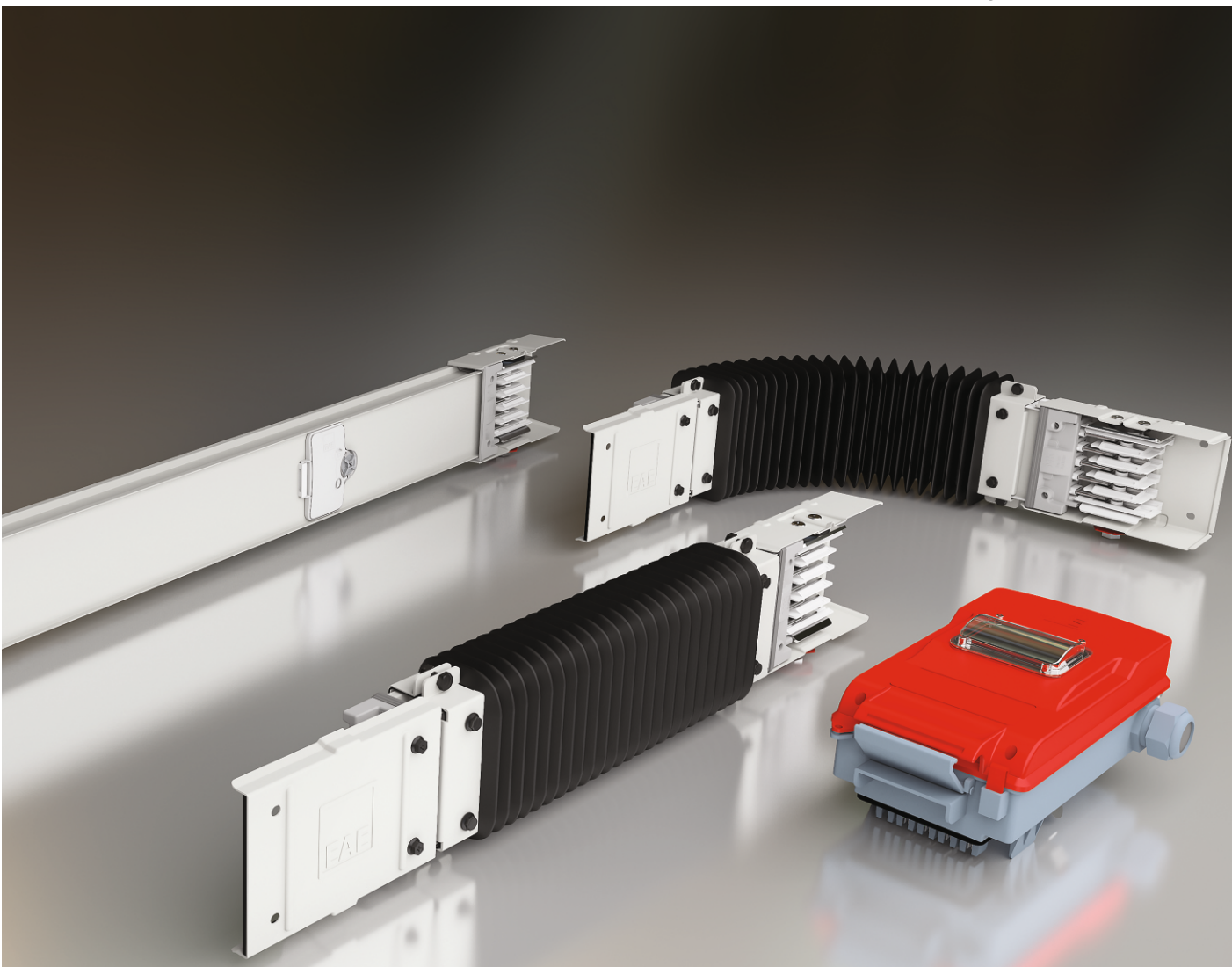

E-LINEMK

Busbar Systems 100-160-225 A



E-LINEMK



►► General Characteristics

The E-Line MK prefabricated busbar trunking system is used as a vertical and horizontal electrical energy distribution system in premises where there is a need for distribution of energy with ratings of 100A-160A-225A. The busbar housing is manufactured from RAL 7038 epoxy painted galvanized sheet metal.

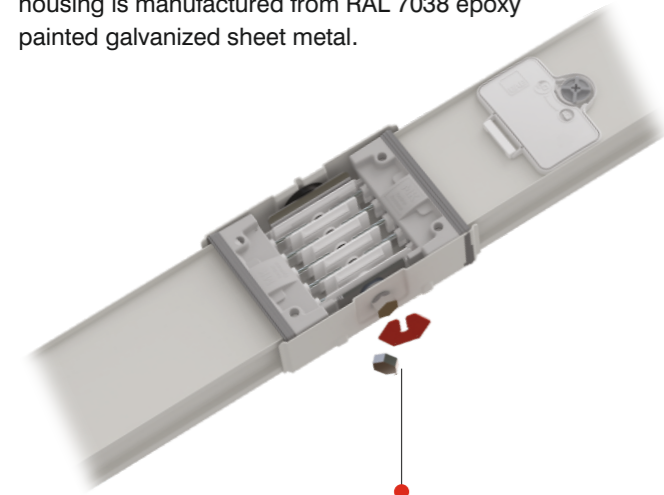

Broken Nut

Special Block Joint

Thanks to the double-head nut, the need for a torque wrench is eliminated. Since the first head of the nut tightened with an ordinary wrench is automatically broken. The first head of the nut will be broken at 20Nm.

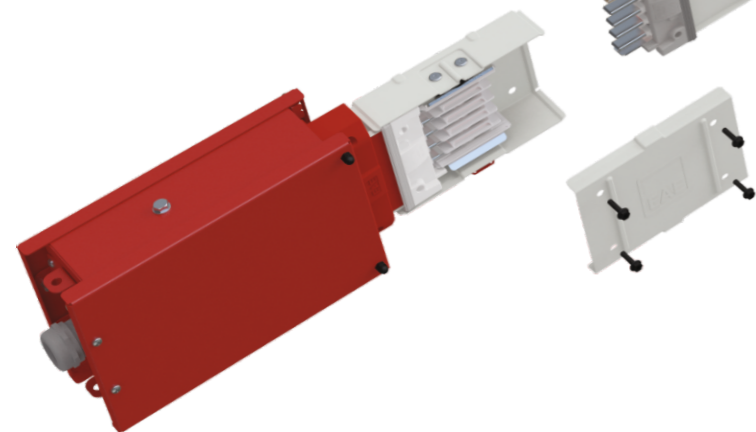

Personell Safety

When either the tapping outlet dust cover, or the tapping box is de-energised (Lid open) the minimum degree of protection IP2X is maintained. This preventing accidental contact with live contacts.

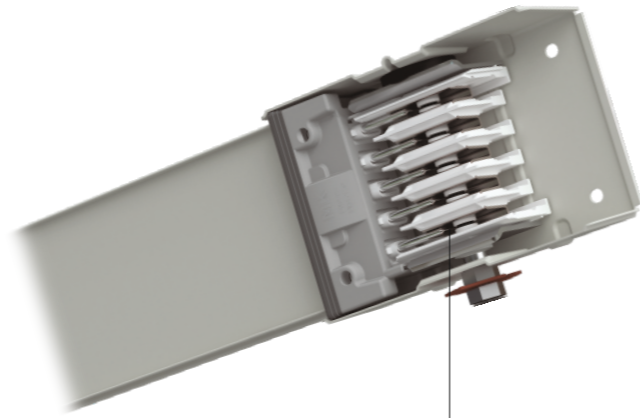

Tin Plated Joint Contacts

Busbar joint contacts are tin plated. The tin plating reduce contact resistance and eliminates overheatings at contact points.

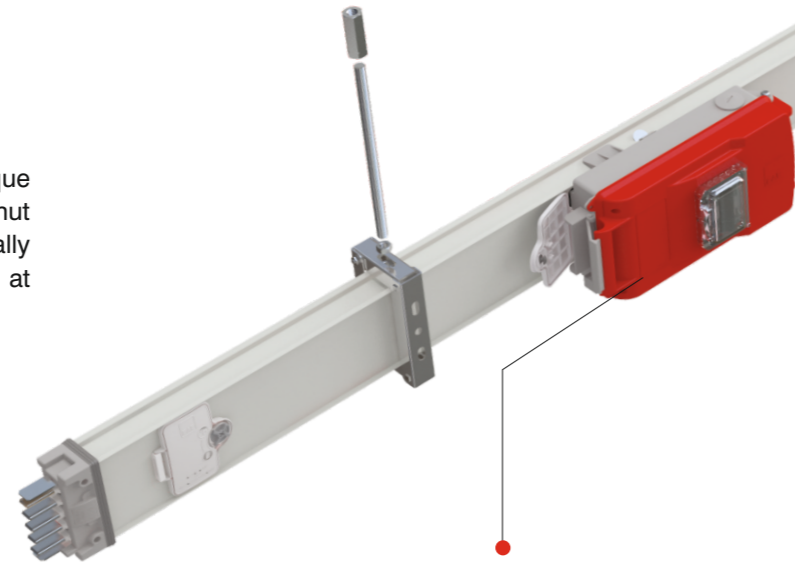

Hinged and Locked IP55 Covers

Tap-off points are protected by IP55 covers againsts water and dust. These covers are fixed to the busbar housing by hinges and single point locker system.

Self-Extinguishing Material for Tap-off Boxes

Tap-off Boxes are manufactured of selfextinguishing (UL V0) and halogen-free plastic material.

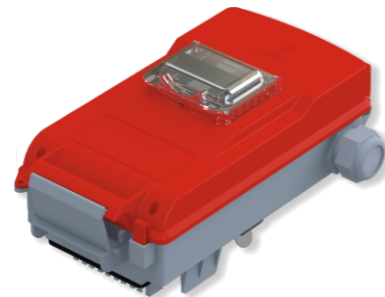

Posibility to get up to 80A energy by using tap-off boxes. Interlock mechanism cuts the energy before opening the lid. Tap-off boxes can be installed safely and easily without additional tool.

10 Current Feeding Windows of Every Length

Provision of a total of 10 Plug-in tapping points on both sides of the busbar are provided as a standard feature.

Plug-in Points

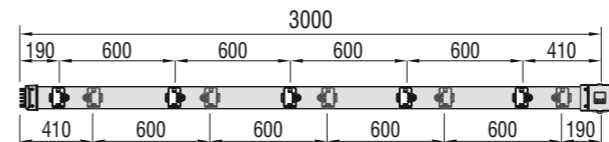

Conductor Configuration

E-Line MK allows application of conductor configurations with options below.

- a- 4 Conductor..... : L1,L2,L3,N,PE(Housing)
- b- 5 Conductor..... : L1,L2,L3,N,PE,PE(Housing)
- c- 5 Conductor clean earth : L1,L2,L3,N,CPE,PE(Housing)

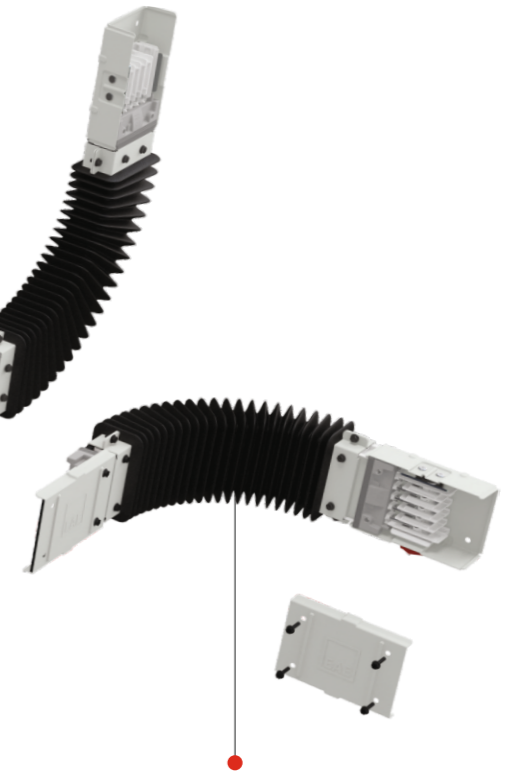

Special Flexible Elbows and Expansion Modules

Vertical and horizontal elbow and dilatation modules are solved by using a single module. Horizontal or vertical elbows at desired angle can be easily accomplished. They are also used safety at the passages of buildings, thanks to their flexibility in every direction.



Full Size Tin Plated Conductors

Copper and aluminium conductors are protected againsts corrosion by continous tin plating at entire length. This application increase the life time of conductors and reduce contact resistances.

Fast and Easy Mounting

The mounting of units does not require any special expertise. Depending on the structure and shape of the building, all necessary accessories can be easily mounted either to the ceiling or wall. "Fast and Easy Mounting" means rapid commissioning of the system.

- BUSBAR TYPE
- CONDUCTOR TYPE
- BUSBAR CURRENT
- PROTECTION DEGREE
- CONDUCTOR CONFIGURATION
- COMPONENT

MK A 16 5 7 - S T D

Busbar Type

Aluminium A
Copper C

Conductor Type

Components

Standard Length	STD
Special Length	X
Flexible Elbow	FD
Expansion Unit	DT
Feeder Box 1	B1
Feeder Box 2	B2
Central Feeder Box	BO

Busbar Rated Current		Code
Aluminium	100	10
	160	16
	225	22
Copper	160	16
	225	22

Busbar Current

IP 55 5

Protection Degree

Conductor Configuration

Number of Conductors	Code	Configuration
4 wire	4	L1,L2,L3,N,PE(Housing)
5 wire	5	L1,L2,L3,N,PE,PE(Housing)
5 wire (Clean Earth)	7	L1,L2,L3,N,CPE,PE(Housing)

Rated Current	In	A	Aluminium Conductor (MKA)			Copper Conductor (MKC)	
			100	160	225	160	225
Busbar Code			10	16	22	16	22
Standards	IEC 61439-6, TS EN 61439-6, IEC 61439-1, TS EN 61439-1						
Rated Isolation Voltage	Ui	V	690				
Max. Rated Operational Voltage	Ue	V	690				
Rated Frequency	f	Hz	50				
Pollution Degree	3						
Protection Degree	IP	55					
External Mechanical Impacts (IK Code)*	Plug-in Busbar IK07						
Rated Short-time Withstand Current (1s)	I _{cw}	kA _(rms)	3,5	6	6	6	10
Rated Peak Withstand Current	I _{pk}	kA	5,25	10,2	10,2	10,2	25
Rated Short-time Withstand Current for Neutral Conductor (1s)	I _{cw}	kA	2,1	3,6	3,6	3,6	7,5
Rated Peak Withstand Current for Neutral Conductor	I _{pk}	kA	3,15	5,4	5,4	5,4	12,75
Rated Short-time Withstand Current for CPE Conductor (1s)	I _{cw}	kA	2,1	3,6	3,6	3,6	7,5
Rated Peak Withstand Current for CPE Conductor	I _{pk}	kA	3,15	5,4	5,4	5,4	12,75
Rated Short-time Withstand Current for PE Conductor (1s)	I _{cw}	kA	2,1	3,6	3,6	3,6	7,5
Rated Peak Withstand Current for PE Conductor	I _{pk}	kA	3,15	5,4	5,4	5,4	12,75
MEAN PHASE CONDUCTOR CHARACTERISTICS AT RATED CURRENT In							
Resistance at a conductor temperature of 20 °C	R ₂₀	mΩ/m	0,640	0,391	0,299	0,405	0,251
Resistance at an ambient air temperature of 35 °C	R	mΩ/m	0,787	0,506	0,411	0,535	0,341
Reactance (Independent from Temperature)	X	mΩ/m	0,154	0,138	0,107	0,158	0,135
Positive and negative sequence impedances at an ambient air temperature of 35 °C	Z	mΩ/m	0,802	0,525	0,425	0,558	0,367
Positive and negative sequence impedances at a conductor temperature of 20 °C	Z ₂₀	mΩ/m	0,658	0,415	0,318	0,435	0,284
Rated Power Loss at 35 °C		W/m	23,4	37,6	62,4	40,3	49,7
DC Resistance at a conductor temperature of 20 °C for Phases	R _{ort_{ph}}	mΩ/m	0,608	0,378	0,306	0,389	0,242
DC Resistance at a conductor temperature of 20 °C for Neutral	R _N	mΩ/m	0,603	0,377	0,317	0,386	0,241
DC Resistance at a conductor temperature of 20 °C for PE	R _{PE}	mΩ/m	0,885	0,885	0,885	0,885	0,885
DC Resistance at a conductor temperature of 20 °C for CPE	R _{CPE}	mΩ/m	0,609	0,378	0,315	0,385	0,242
SECTIONS							
L1,L2,L3,N		mm ²	47,25	76,50	108,00	47,25	76,50
PE (5 Conductors)		mm ²	47,25	76,50	108,00	47,25	76,50
PE (Sheet Metal)		mm ²	198	198	198	198	198
Conductor Dimensions		mmxmm	4,5x10,5	4,5x17	4,8x22,5	4,5x10,5	4,5x17
Busbar Weight (4 Conductors)		kg/m	2,35	2,70	3,23	3,30	4,50
Busbar Weight (5 Conductors)		kg/m	2,50	2,90	4,08	3,70	5,20
MEAN FAULT-LOOP CHARACTERISTICS							
Zero-sequence Impedance							
Zero-sequence impedance at a conductor temperature of 20 °C	Z _{(0) b20pH}	mΩ/m	2,801	1,866	1,512	1,984	1,409
Zero-sequence impedance at a conductor temperature of 20 °C	Z _{(0) b20pHPE}	mΩ/m	3,781	3,284	2,998	3,186	3,050
Zero-sequence impedance at a conductor temperature of 20 °C	Z _{(0) b20pHCPE}	mΩ/m	2,774	1,878	1,519	1,967	1,406
Zero-sequence impedance at an ambient temperature of 35 °C	Z _{(0) bphN}	mΩ/m	3,386	2,357	1,954	2,474	1,765
Zero-sequence impedance at an ambient temperature of 35 °C	Z _{(0) bphPE}	mΩ/m	4,570	4,235	4,105	4,052	4,040
Zero-sequence impedance at an ambient temperature of 35 °C	Z _{(0) bphCPE}	mΩ/m	3,350	2,374	1,956	2,453	1,759
Resistances and Reactances							
Resistance at a conductor temperature of 20 °C	R _{b20pHph}	mΩ/m	1,265	0,780	0,613	0,819	0,523
Resistance at a conductor temperature of 20 °C	R _{b20pHN}	mΩ/m	1,278	0,792	0,625	0,831	0,533
Resistance at a conductor temperature of 20 °C	R _{b20pHPE}	mΩ/m	1,587	1,384	1,118	1,436	1,152
Resistance at a conductor temperature of 20 °C	R _{b20pHCPE}	mΩ/m	1,280	0,794	0,627	0,830	0,533
Resistance at an ambient air temperature of 35 °C	R _{bphph}	mΩ/m	1,557	1,030	0,836	1,072	0,708
Resistance at an ambient air temperature of 35 °C	R _{bphN}	mΩ/m	1,573	1,045	0,853	1,087	0,722
Resistance at an ambient air temperature of 35 °C	R _{bphPE}	mΩ/m	1,954	1,827	1,765	1,879	1,560
Resistance at an ambient air temperature of 35 °C	R _{bphCPE}	mΩ/m	1,575	1,048	0,856	1,085	0,722
Reactance (Independent from temperature)	X _{bphph}	mΩ/m	0,302	0,261	0,235	0,311	0,268
Reactance (Independent from temperature)	X _{bphN}	mΩ/m	0,392	0,374	0,343	0,420	0,380
Reactance (Independent from temperature)	X _{bphPE}	mΩ/m	0,446	0,491	0,468	0,633	0,558
Reactance (Independent from temperature)	X _{bphCPE}	mΩ/m	0,379	0,367	0,344	0,424	0,376

* Joint weight is included rated 1/3 of the weight of the joint in the indicated weights per meter.

▶▶ Standard Straight Length Dimensions

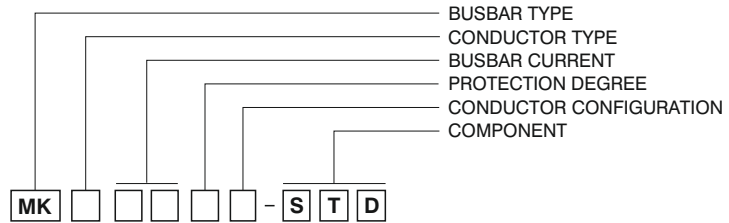

Standard length of busbar is 300cm.

Provision of a total of 10 plug-in points on both sides of the busbar are provided as a standard feature.

Sample Order:
160A, Aluminium, IP55, 4 conductors
MKA 1654-STD

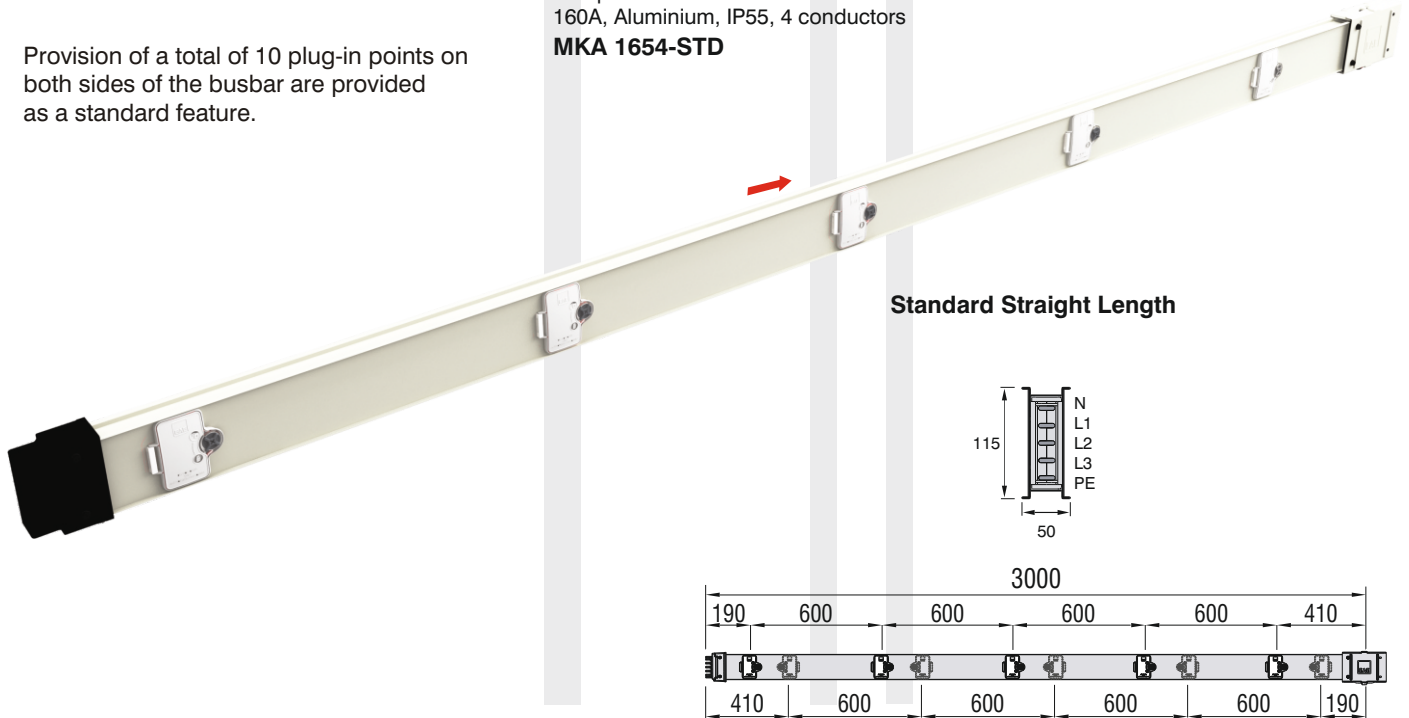

Standard Straight Length

STD-Standard Length Busbar / Codes

Current (A)	Conductors	Aluminium (Al)	Configuration	Code
100	4	MKA 1054 Busbar	L1, L2, L3, N, PE(Housing)	3024402
	5	MKA 1055 Busbar	L1, L2, L3, N, PE+Housing	3024401
	5	MKA 1057 Busbar	L1, L2, L3, N, CPE, PE(Housing)	3024400
160	4	MKA 1654 Busbar	L1, L2, L3, N, PE(Housing)	3024741
	5	MKA 1655 Busbar	L1, L2, L3, N, PE+Housing	3024737
	5	MKA 1657 Busbar	L1, L2, L3, N, CPE, PE(Housing)	3024689
225	4	MKA 2254 Busbar	L1, L2, L3, N, PE(Housing)	3164718
	5	MKA 2255 Busbar	L1, L2, L3, N, PE+Housing	3164719
	5	MKA 2257 Busbar	L1, L2, L3, N, CPE, PE(Housing)	3176276

Current (A)	Conductors	Copper (Cu)	Configuration	Code
160	4	MKC 1654 Busbar	L1, L2, L3, N, PE(Housing)	3024743
	5	MKC 1655 Busbar	L1, L2, L3, N, PE+Housing	3024739
	5	MKC 1657 Busbar	L1, L2, L3, N, CPE, PE(Housing)	3024691
225	4	MKC 2254 Busbar	L1, L2, L3, N, PE(Housing)	3024742
	5	MKC 2255 Busbar	L1, L2, L3, N, PE+Housing	3024738
	5	MKC 2257 Busbar	L1, L2, L3, N, CPE, PE(Housing)	3024690

►► Special Straight Length Dimensions

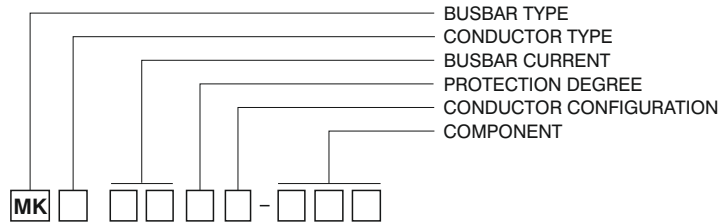

Current Aluminium Copper		
(A)	(A) mm	(A) mm
100	10,5	6
160	17	10,5
225	22,5	17

Conductor Cross Sections
For non-standard modules, please contact our company.

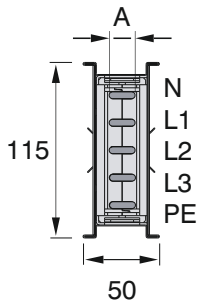

Sample Order:
225A, Copper, IP55, 5 conductors, 100cm.
MKC 2255-100

Special straight length busbars are manufactured as standard at 1m, 1,5m and 2m.

Minimum Special Straight Length:
without plug-in point 500mm
with plug-in point 1000mm

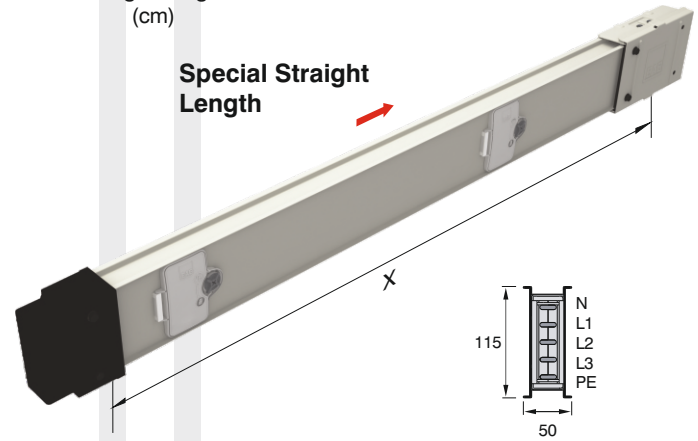
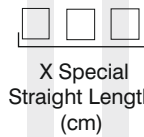

X-Special Straight Length Busbar / Codes

Current (A)	Conductors	Aluminium (Al)	Configuration	Code
100	4	MKA 1054-X Special straight length	L1, L2, L3, N, PE(Housing)	3024396
	5	MKA 1055-X Special straight length	L1, L2, L3, N, PE+Housing	3024397
	5	MKA 1057-X Special straight length	L1, L2, L3, N, CPE, PE(Housing)	3024395
160	4	MKA 1654-X Special straight length	L1, L2, L3, N, PE(Housing)	3024710
	5	MKA 1655-X Special straight length	L1, L2, L3, N, PE+Housing	3024706
	5	MKA 1657-X Special straight length	L1, L2, L3, N, CPE, PE(Housing)	3024685
225	4	MKA 2254-X Special straight length	L1, L2, L3, N, PE(Housing)	3176277
	5	MKA 2255-X Special straight length	L1, L2, L3, N, PE+Housing	3176278
	5	MKA 2257-X Special straight length	L1, L2, L3, N, CPE, PE(Housing)	3176279

Current (A)	Conductors	Copper (Cu)	Configuration	Code
160	4	MKC 1654-X Special straight length	L1, L2, L3, N, PE(Housing)	3024712
	5	MKC 1655-X Special straight length	L1, L2, L3, N, PE+Housing	3024708
	5	MKC 1657-X Special straight length	L1, L2, L3, N, CPE, PE(Housing)	3024687
225	4	MKC 2254-X Special straight length	L1, L2, L3, N, PE(Housing)	3024711
	5	MKC 2255-X Special straight length	L1, L2, L3, N, PE+Housing	3024707
	5	MKC 2257-X Special straight length	L1, L2, L3, N, CPE, PE(Housing)	3024686

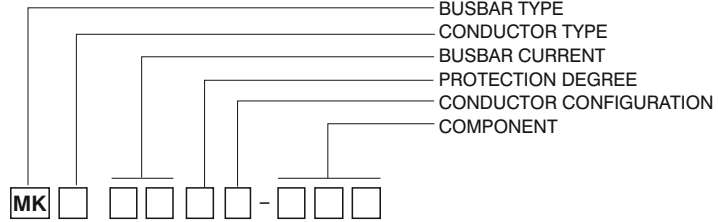

Sample Order:
225A, Copper IP55, 4 conductors

MKC 2254 - FD

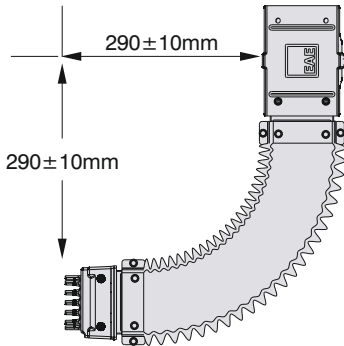

Flexible Elbow (Vertical)

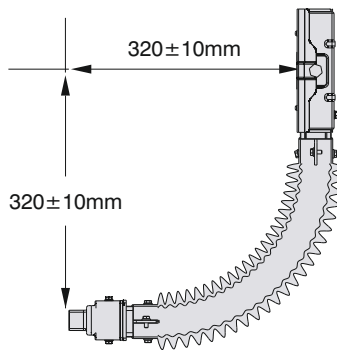
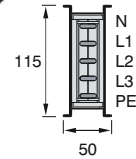

Flexible Elbow (Horizontal)

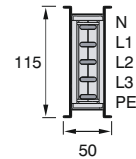
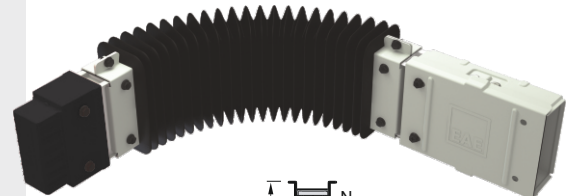

FD Flexible Elbow (Al/Cu)

Current(A)	Conductors	Copper (Cu)	Code
100 Al	4	MKA 1054-FD Flexible Elbow	3024723
	5	MKA 1055-FD Flexible Elbow	3024721
	5	MKA 1057-FD Flexible Elbow	3024697
160 Al 160 Cu 225 Cu	4	MKC 2254-FD Flexible Elbow	3024724
	5	MKC 2255-FD Flexible Elbow	3024722
	5	MKC 2257-FD Flexible Elbow	3024698
225 Al	4	MKA 2254-FD Flexible Elbow	3176289
	5	MKA 2255-FD Flexible Elbow	3176290
	5	MKA 2257-FD Flexible Elbow	3176291

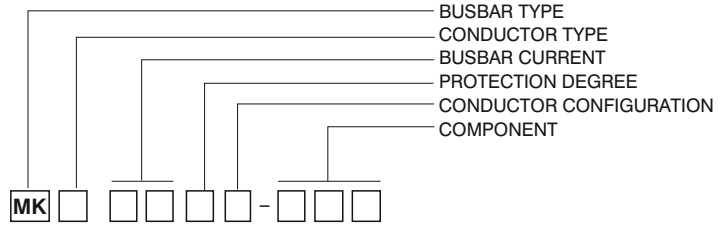

Sample Order:
160A, Copper, IP55, 4 conductors

MKC 1654 - DT

DT Expansion Unit (Horizontal and vertical)

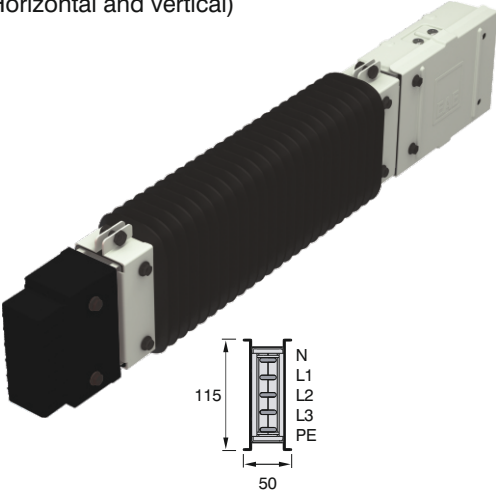
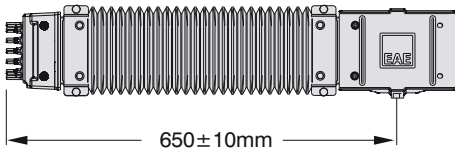

DT Expansion Unit (Al/Cu)

Current(A)	Conductors	Copper (Cu)	Code
100 Al	4	MKA 1054-DT Expansion	3024715
	5	MKA 1055-DT Expansion	3024714
	5	MKA 1057-DT Expansion	3024696
160 Al 160 Cu 225 Cu	4	MKC 2254-DT Expansion	3024720
	5	MKC 2255-DT Expansion	3024719
	5	MKC 2257-DT Expansion	3024699
225 Al	4	MKA 2254-DT Expansion	3176292
	5	MKA 2255-DT Expansion	3176293
	5	MKA 2257-DT Expansion	3176294

►► Feeder Boxes Codes

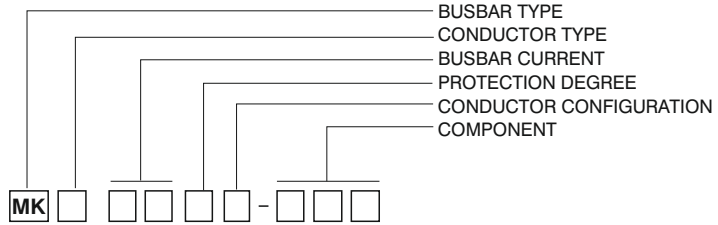

Sample Order:
160A, Copper IP55, 5 conductors

MKC 1655 - B1

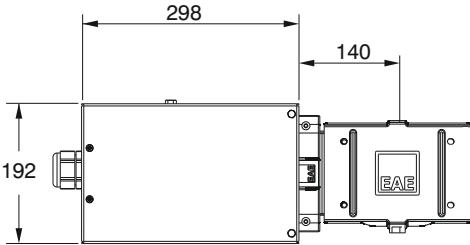
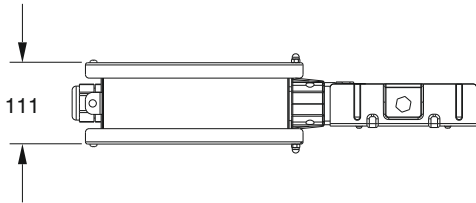

B1 Feeder Box 1

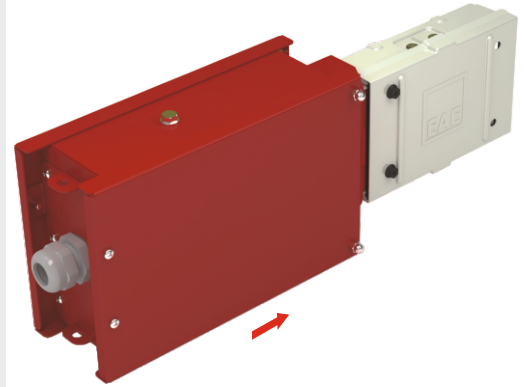
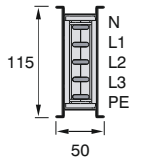

Cable Gland Plates

Current (A)	Material	Cable Gland Type	Inner Diameter (mm)
100	Al	M32	25
*160	Al	M40	32
225	Al	M50	38

*Gland plates are manufactured as per M40 gland unless it is specified during order.

B1 Feeder Box 1 (Al)

Current(A)	Conductors	Aluminium (Al)	Code
100 Al 160 Al	4	MKA 1654-B1 Feeder Box 1	3024735
	5	MKA 1655-B1 Feeder Box 1	3024729
	5	MKA 1657-B1 Feeder Box 1	3024704
225 Al	4	MKA 2254-B1 Feeder Box 1	3176280
	5	MKA 2255-B1 Feeder Box 1	3176281
	5	MKA 2257-B1 Feeder Box 1	3176282

B1 Feeder Box 1 (Cu)

Current(A)	Conductors	Copper (Cu)	Code
160 Cu 225 Cu	4	MKC 2254-B1 Feeder Box 1	3024736
	5	MKC 2255-B1 Feeder Box 1	3024730
	5	MKC 2257-B1 Feeder Box 1	3024705

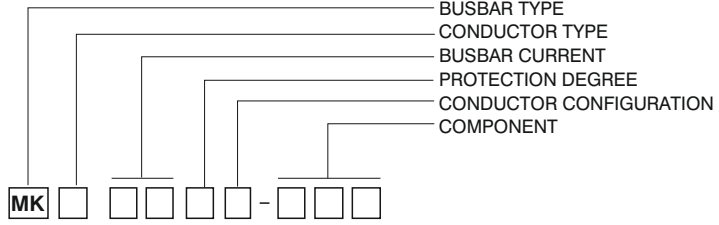

Sample Order:
160A, Aluminium IP55, 4 conductor

MKA 1654 - B2

B2 Feeder Box 2

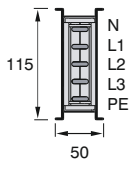
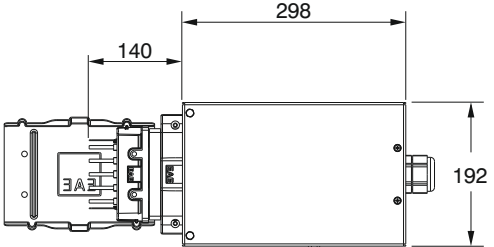
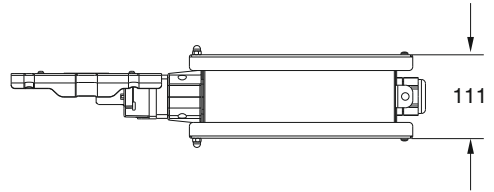
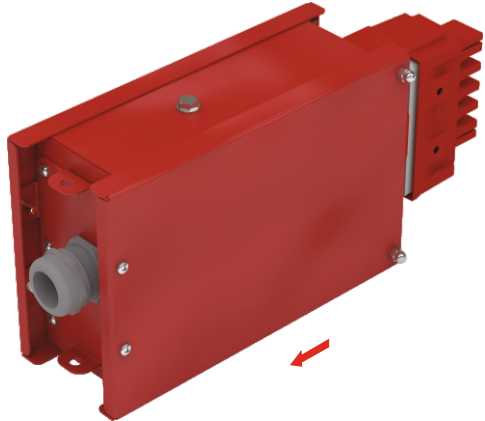

Cable Gland Plates

Current (A)	Material	Cable Gland Type	Inner Diameter (mm)
100	Al	M32	25
*160	Al	M40	32
225	Al	M50	38

*Gland plates are manufactured as per M40 gland unless it is specified during order.

B2 Feeder Box 2 (Al)

Current(A)	Conductors	Aluminium (Al)	Code
100 Al 160 Al	4	MKA 1654-B2 Feeder Box 2	3024733
	5	MKA 1655-B2 Feeder Box 2	3024727
	5	MKA 1657-B2 Feeder Box 2	3024702
225 Al	4	MKA 2254-B2 Feeder Box 2	3176283
	5	MKA 2255-B2 Feeder Box 2	3176284
	5	MKA 2257-B2 Feeder Box 2	3176285

B2 Feeder Box 2 (Cu)

Current(A)	Conductors	Copper (Cu)	Code
160 Cu 225 Cu	4	MKC 2254-B2 Feeder Box 2	3024734
	5	MKC 2255-B2 Feeder Box 2	3024728
	5	MKC 2257-B2 Feeder Box 2	3024703

►► Feeder Boxes Codes

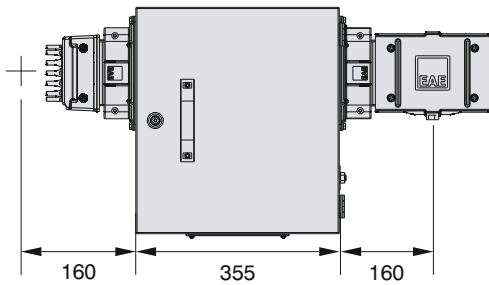
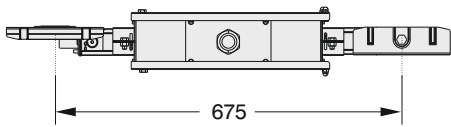
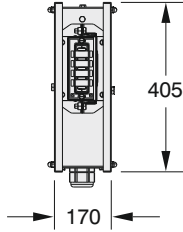
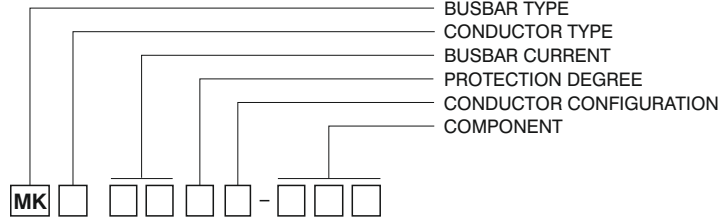

Sample Order:
160A, Aluminium, IP55, 4 conductors
MKA 1654-BO

BO-Central Feeder Box

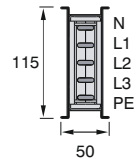
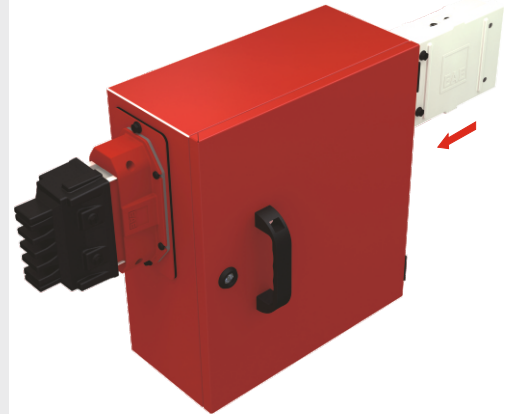

Cable Gland Plates

Current (A)	Material	Cable Gland Type	Inner Diameter (mm)
100	Al	M32	25
*160	Al	M40	32
225	Al	M50	38

*Gland plates are manufactured as per M40 gland unless it is specified during order.

BO-Central Feeder Box (Al)

Current(A)	Conductors	Aluminium (Al)	Code
100 Al 160 Al	4	MKA 1654-BO Central F.B.	3024731
	5	MKA 1655-BO Central F.B.	3024725
	5	MKA 1657-BO Central F.B.	3024700
225 Al	4	MKA 2254-BO Central F.B.	3176286
	5	MKA 2255-BO Central F.B.	3176287
	5	MKA 2257-BO Central F.B.	3176288

BO-Central Feeder Box (Cu)

Current(A)	Conductors	Copper (Cu)	Code
160 Cu 225 Cu	4	MKC 2254-BO Central F.B.	3024732
	5	MKC 2255-BO Central F.B.	3024726
	5	MKC 2257-BO Central F.B.	3024701

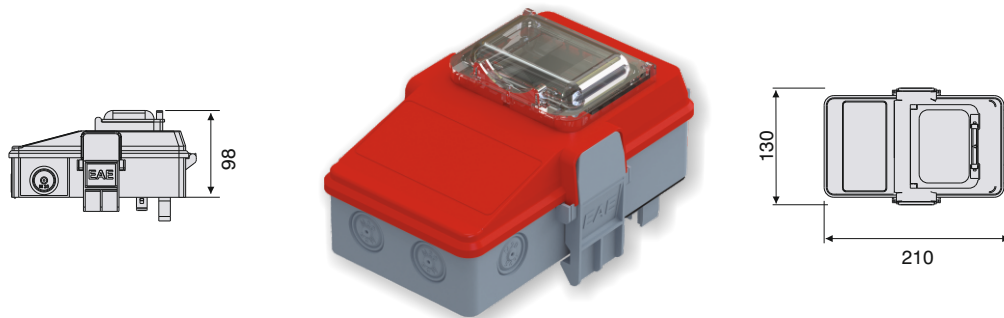
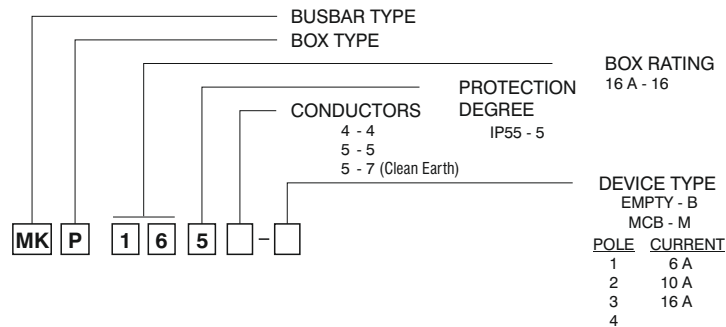

Standard Tap-Off Boxes (EMPTY)

Current(A)	Conductors	Description	Configuration	Device	Code
16	4	MKP 1654-B Tap-Off Box	L1, L2, L3, N, PE(Housing)	Suitable for MCB/Fuse holder	3024695
	5	MKP 1655-B Tap-Off Box	L1, L2, L3, N, PE+Housing		3024694
	5	MKP 1657-B Tap-Off Box	L1, L2, L3, N, CPE, PE(Housing)		3024693

- Maximum size of outgoing cable Ø13 mm.
- For non-standard tap off boxes, please contact our company.

Standard Tap-Off Boxes (MCB)

Current(A)	Conductors	Description	Configuration	Device	Code
16	4	MKP 1654-M Tap-Off Box	L1, L2, L3, N, PE(Housing)	1x16A with MCB	3024677
		MKP 1654-M Tap-Off Box		3x16A with MCB	3024668
	5	MKP 1655-M Tap-Off Box	L1, L2, L3, N, PE+Housing	1x16A with MCB	3024676
		MKP 1655-M Tap-Off Box		3x16A with MCB	3024667
	5	MKP 1657-M Tap-Off Box	L1, L2, L3, N, CPE, PE(Housing)	1x16A with MCB	3024675
		MKP 1657-M Tap-Off Box		3x16A with MCB	3024666

- Maximum size of outgoing cable Ø13 mm.

Tap-off boxes with sockets are supplied with 16A MCB as standard. For the tap-off boxes with sockets, please contact to supplier.
Warning: For balancing phase loads, please calculate and select the correct tap-off box types and quantities.

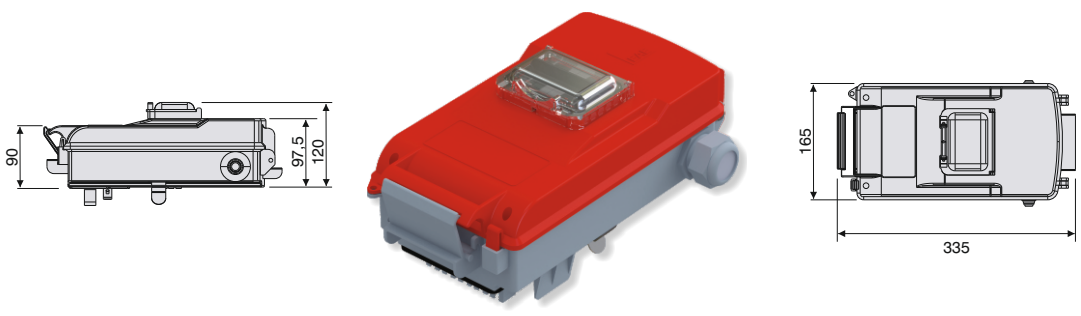
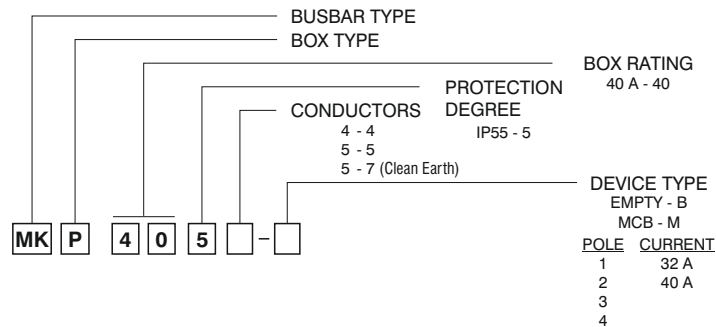

Standard Tap-Off Boxes (EMPTY)

Current(A)	Conductors	Description	Configuration	Device	Code
40	4	MKP 4054-B Tap-Off Box	L1, L2, L3, N, PE(Housing)	Suitable for MCB/Fuse holder	3024665
	5	MKP 4055-B Tap-Off Box	L1, L2, L3, N, PE+Housing		3024664
	5	MKP 4057-B Tap-Off Box	L1, L2, L3, N, CPE, PE(Housing)		3024663

- Maximum size of outgoing cable Ø22 mm.
- For non-standard output boxes, please contact our company.

Standard Tap-Off Boxes (MCB)

Current(A)	Conductors	Description	Configuration	Device	Code
40	4	MKP 4054-M Tap-Off Box	L1, L2, L3, N, PE(Housing)	3 x 40A with MCB	3024662
	5	MKP 4055-M Tap-Off Box	L1, L2, L3, N, PE+Housing		3024661
	5	MKP 4057-M Tap-Off Box	L1, L2, L3, N, CPE, PE(Housing)		3024660

- As standard with 3x40A automatic fuse is used in boxes.
- Maximum size of outgoing cable Ø22 mm.

Tap-off boxes with sockets are supplied with 40A MCB as standard. For the tap-off boxes with sockets, please contact to supplier.
Warning: For balancing phase loads, please calculate and select the correct tap-off box types and quantities.

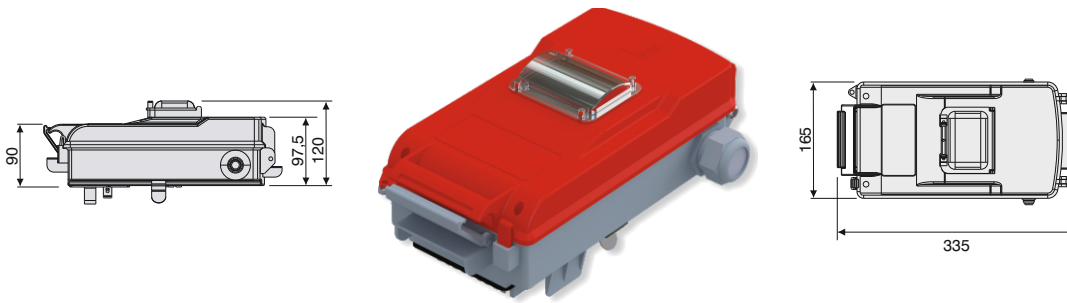
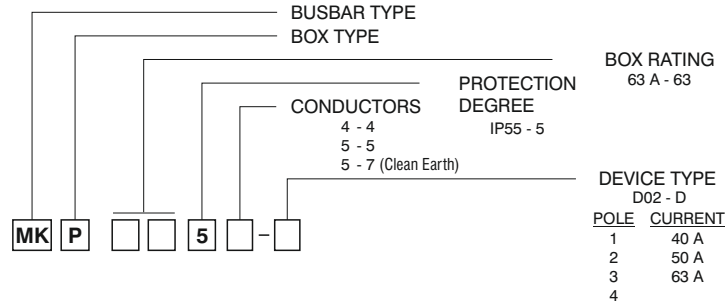

Standard Tap-Off Boxes (D02)

Current(A)	Conductors	Description	Configuration	Device	Code
63	4	MKP 6354-D Tap-Off Box	L1, L2, L3, N, PE(Housing)	3x63 A	3024623
	5	MKP 6355-D Tap-Off Box	L1, L2, L3, N, PE+Housing	D02 Type	3024631
	5	MKP 6357-D Tap-Off Box	L1, L2, L3, N, CPE, PE(Housing)	Fuse Base	3024630

• Maximum size of outgoing cable Ø22 mm. • As standard with 3x63A D02 type fuse base is used in boxes. For output boxes with plug, please contact our company.

Warning: For balancing phase loads, please calculate and select the correct tap-off box types and quantities.

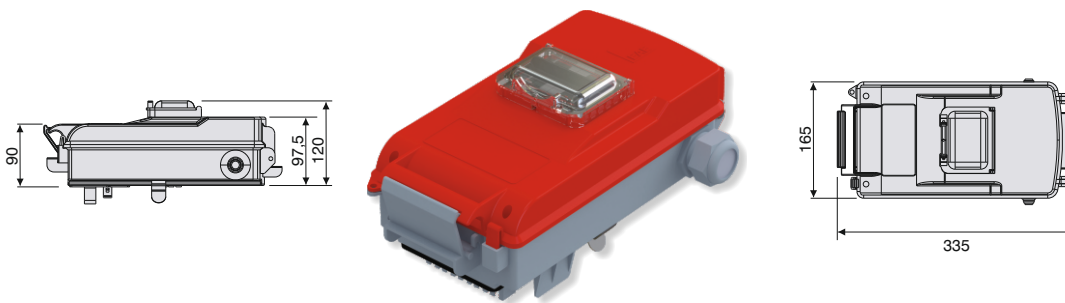
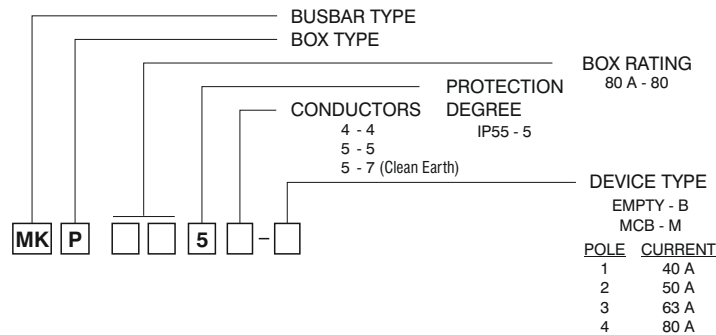

Standard Tap-Off Boxes (EMPTY)

Current(A)	Conductors	Description	Configuration	Device	Code
80	4	MKP 8054-B Tap-Off Box	L1, L2, L3, N, PE(Housing)	Suitable for MCB/Fuse holder	3024718
	5	MKP 8055-B Tap-Off Box	L1, L2, L3, N, PE+Housing		3024717
	5	MKP 8057-B Tap-Off Box	L1, L2, L3, N, CPE, PE(Housing)		3024716

Standard Tap-Off Boxes (MCB)

Current(A)	Conductors	Description	Configuration	Device	Code
80	4	MKP 8054-M Tap-Off Box	L1, L2, L3, N, PE(Housing)	3 x 80A with MCB	3024659
	5	MKP 8055-M Tap-Off Box	L1, L2, L3, N, PE+Housing		3024658
	5	MKP 8057-M Tap-Off Box	L1, L2, L3, N, CPE, PE(Housing)		3024657

- As standard with 3x80A MCB.
- Maximum size of outgoing cable Ø22 mm.

Tap-off boxes with sockets are supplied with 80A MCB as standard. For the tap-off boxes with sockets, please contact to supplier.
Warning: For balancing phase loads, please calculate and select the correct tap-off box types and quantities.

▶▶ Tap off Boxes (MKP-DATA) (80A)

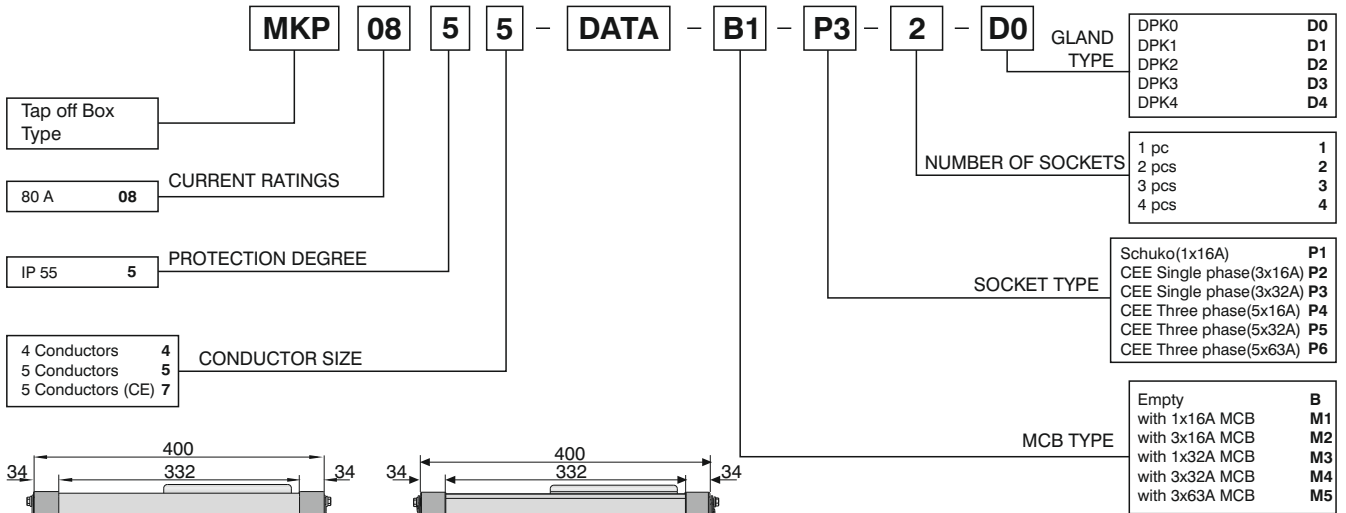

Features;

- Up to 80A MCB
- RAL 7038 Painted Aluminium Housing
- Standard tap-off is empty, gland plates are DPK0.
- with DIN rail inside(available for 4pcs 3P MCB)
- May be equipped with CEE or Schuko Sockets with different configurations. (Optional)
- All tap off boxes with equipment fitted are manufactured with C Type ABB MCB.

Cable Gland Plates

Mat.	Cable Gland Type	Order Code	Inner Diameter (mm)
Al	----	DPK0	---
Al	M16	DPK1	10
Al	10xM16	DPK2	10
Al	M25	DPK3	18
Al	4xM25	DPK4	18

Standard Tap-Off Boxes (EMPTY)

Current(A)	Conductors	Description	Configuration	Device	Code
80	4	MKP 8054-DATA-B1 Tap-off Box	L1, L2, L3, N, PE(Housing)	Suitable for MCB	3046458
	5	MKP 8055-DATA-B1 Tap-off Box	L1, L2, L3, N, PE+Housing		3043818
	5	MKP 8057-DATA-B1 Tap-off Box	L1, L2, L3, N, CPE, PE(Housing)		3063567

- Maximum size of outgoing cable Ø22 mm.
- For non-standard output boxes, please contact our company.

For the tap-off boxes with sockets and MCB, please contact to supplier.

Note: For balancing phase loads, please calculate and select the correct tap-off box types and quantities.

Description	Code
BRA9-2 Steel Dowel (M8)	5000033
BRA10 Extension Unit (M8)	1004313
BRA11-05 Threaded Rod (M8x500)	5000039
BRA11-10 Threaded Rod (M8x1000)	5000038
BRA11-15 Threaded Rod (M8x1500)	5000035
BRA11-20 Threaded Rod (M8x2000)	5000036

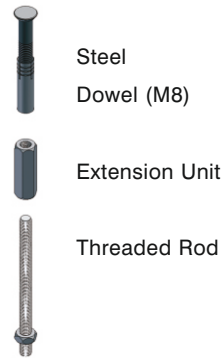

Fixing Elements

Description	Code
MK-UT Universal Fixing Element	2052178

Steel Dowel (M8)

Extension Unit

Threaded Rod

MK-UT Universal Fixing Element



Roof Installation

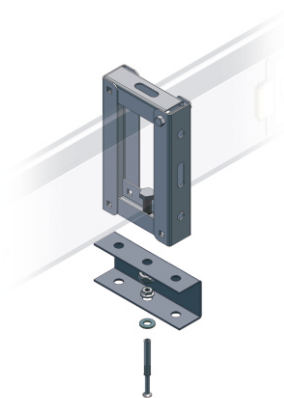

Floor Installation

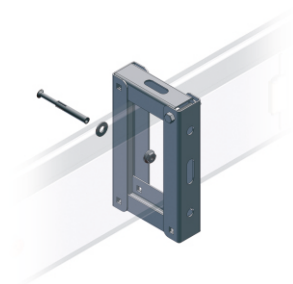

Wall Installation

Fixing Elements

Description	Code
MK "C" Type Universal Fixing Element	1004188

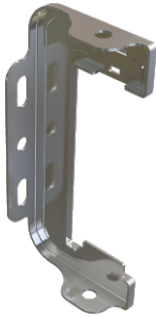

Steel
Dowel (M8)

Extension Unit

Threaded Rod

MK
"C" Type
Universal
Fixing
Element



Roof Installation



Floor Installation

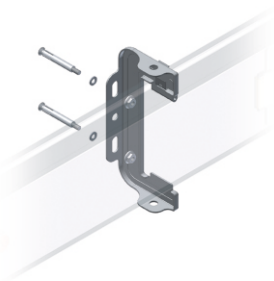

Wall Installation

Description	Code
MK Vertical Fixing Element	3025370

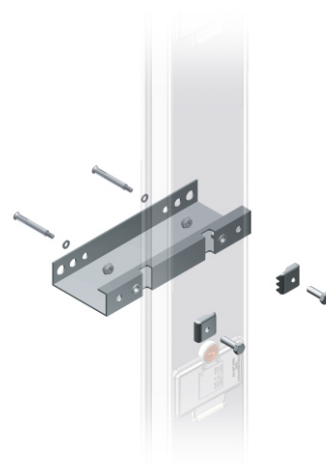
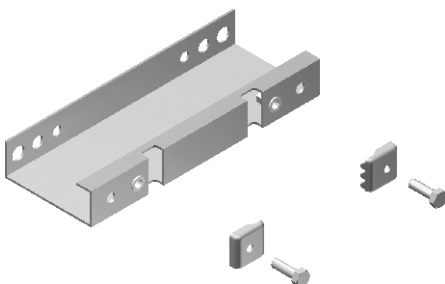

Vertical Shaft Installation

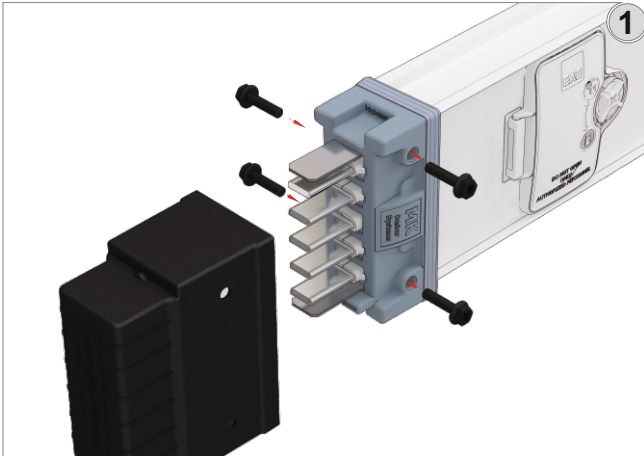

Remove the protective plastic cover.
(These covers are for transportation purpose and required number of covers should be used as END CLOSER unit.)

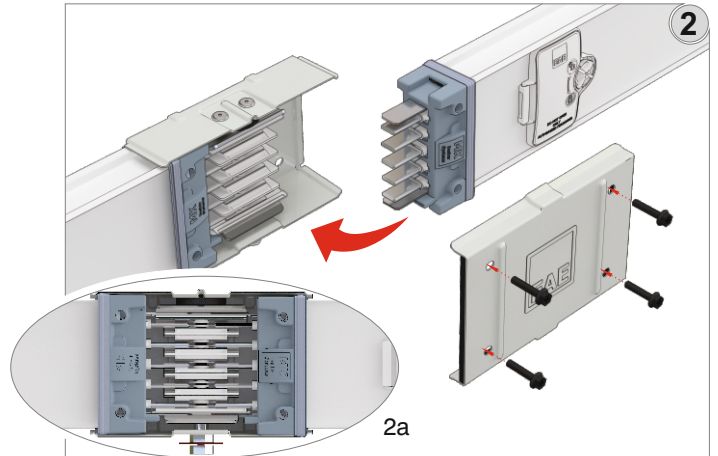

Alligne two busbars like the picture-2a and insert the busbar conductors into the block joint.

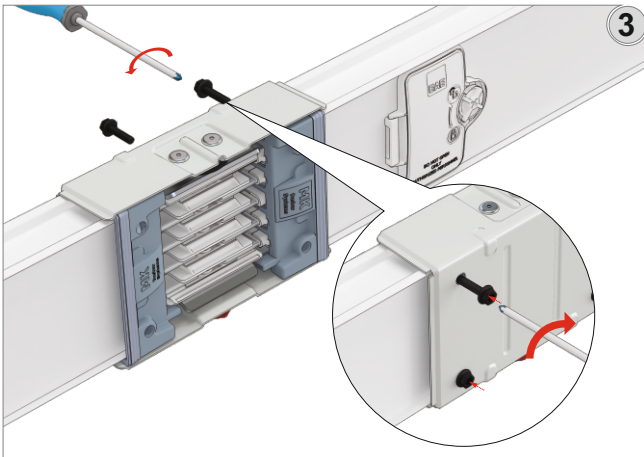

Tighten the bolts of rear cover. (3a)

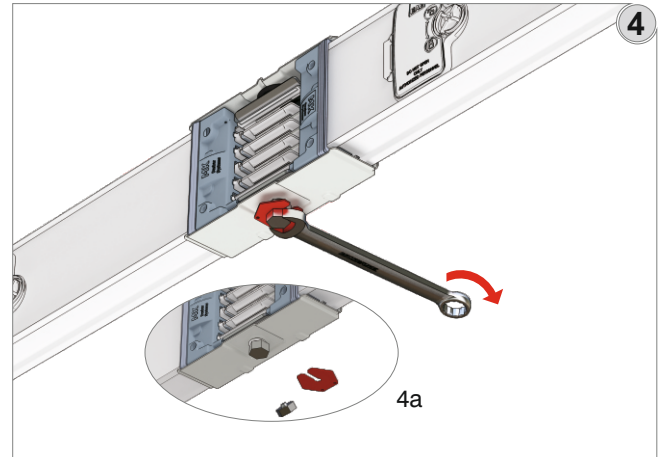

Tighten the main bolt until the first nut is broken. (4a)

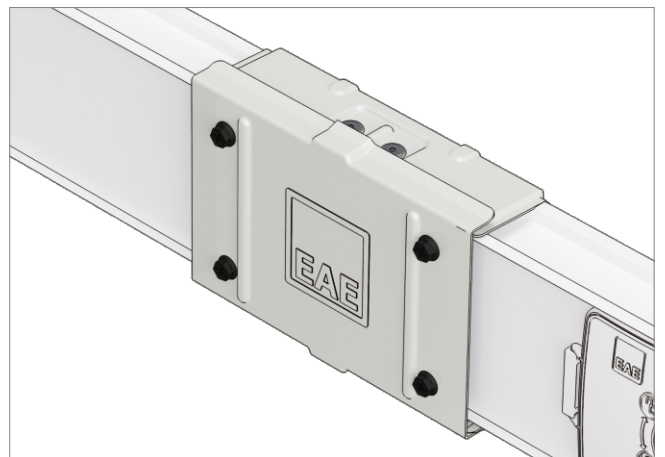
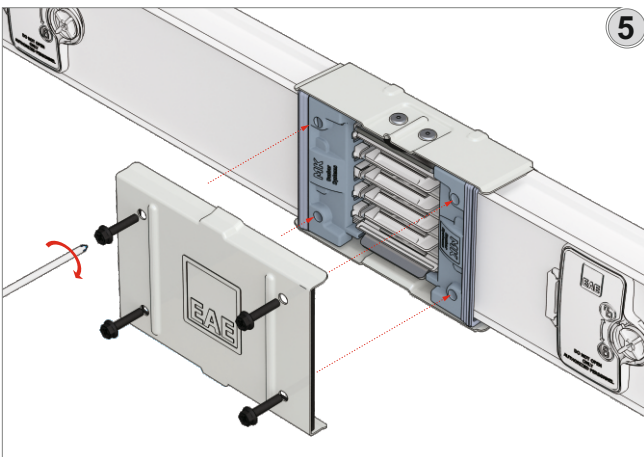



Attach the cable, which has a cross section suitable to the switch current, before you install the box to the busbar.

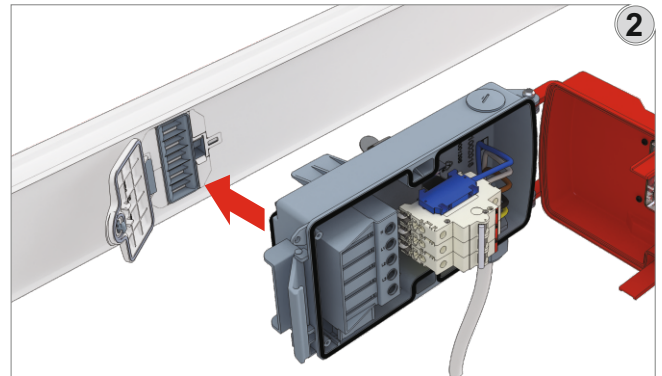

When the tap-off box cover is at open position; locate the box contacts to the busbar plug area by aligning them.

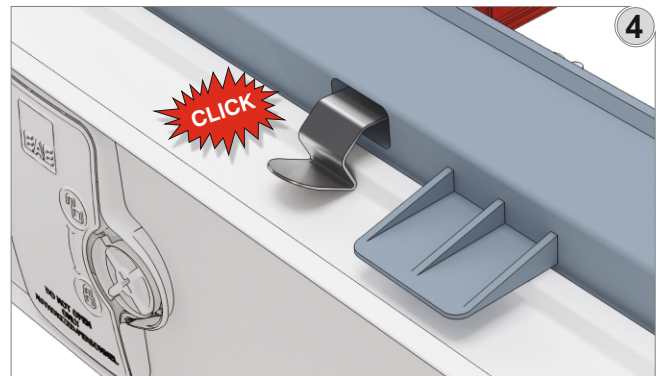
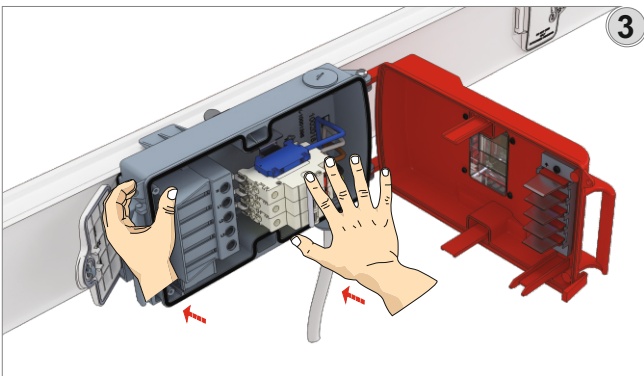

Be sure that the retaining springs are attached to the busbar

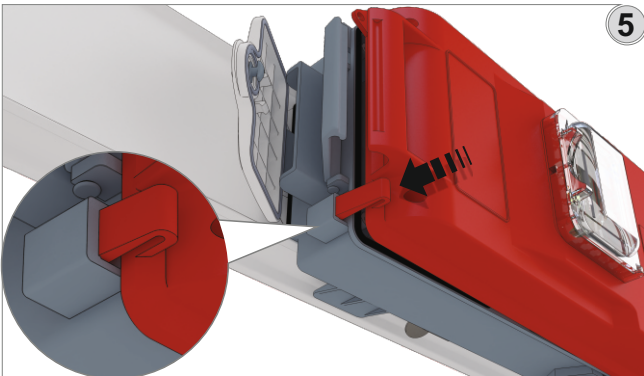

When closing the cover of the box; insert the safety-tongue into the seat by finger touch.

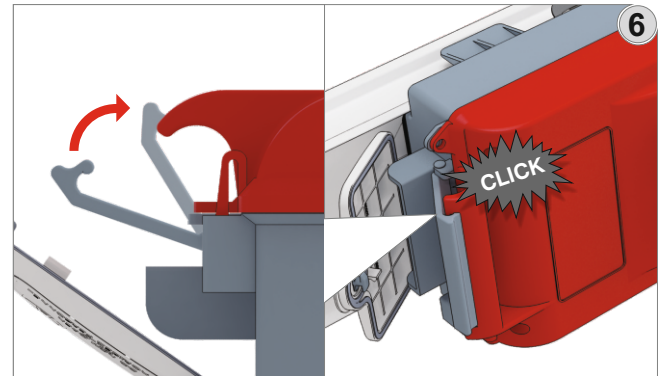

Lock the cover lock by pressing it towards the arrow direction.

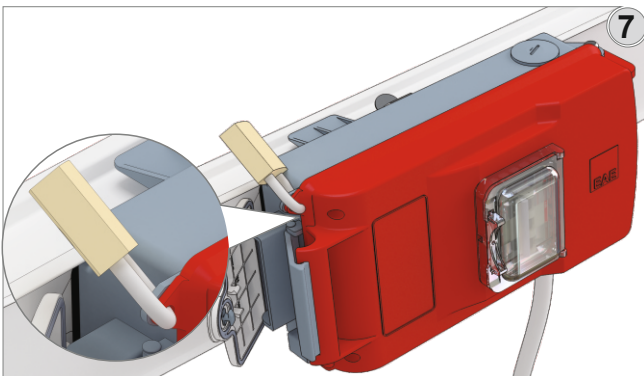

Take cover box with lock for safety.

- Empty tap-off boxes are produced with MCB connection cables.
- When the tap-off boxes are used as single phase, the switch will be connected to one of the phase cables.
- Remaining phase cables should be insulated by using cable terminals for your safety. In order to balance phases of busbar, connected loads to the tap off boxes should be calculated carefully.

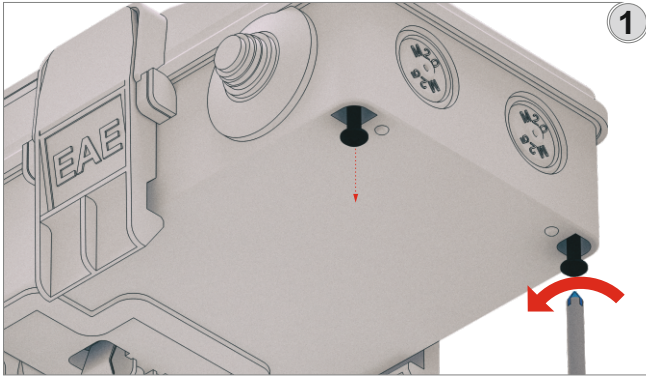

1- Remove the cover screws.

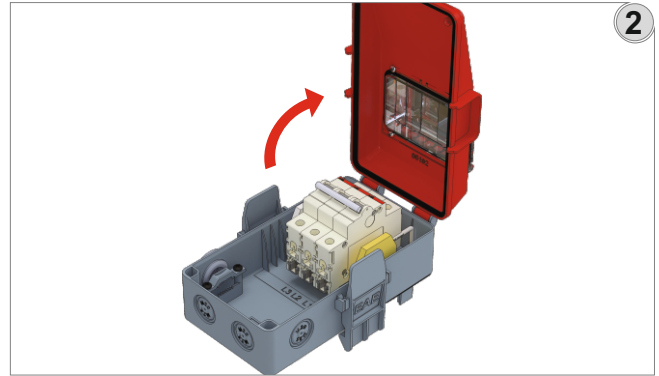

2- Open the cover.

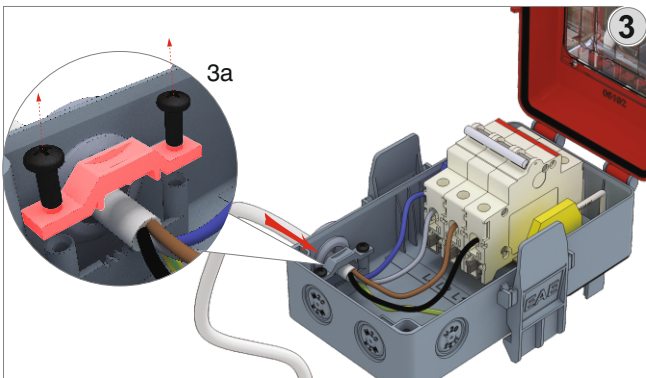

3- Connect a cable, which has suitable cross section, to the switch, before you install the box to the busbar.

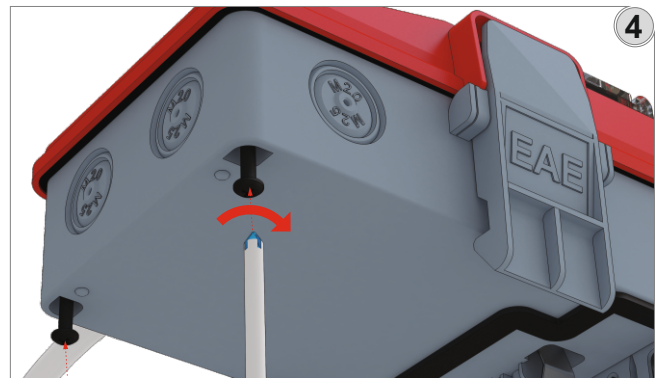

4- Tighten the removed cover screws.

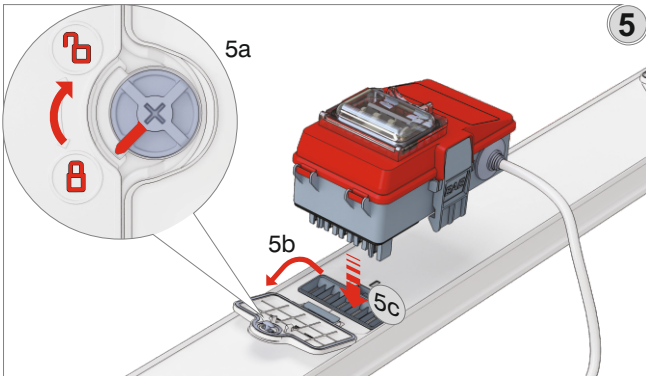

5- Fix the box contacts to the busbar plug area by aligning them.

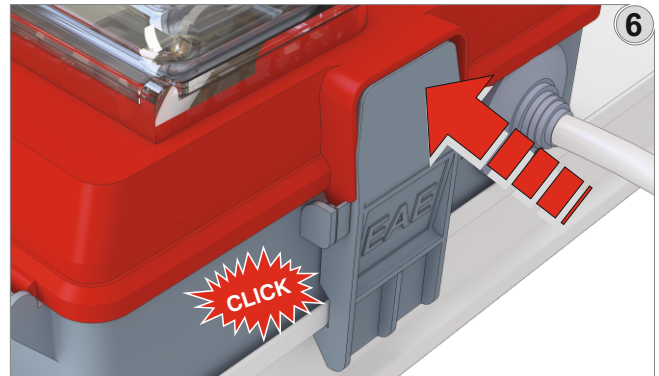

6- Be sure that, the box is fixed to the busbar properly.

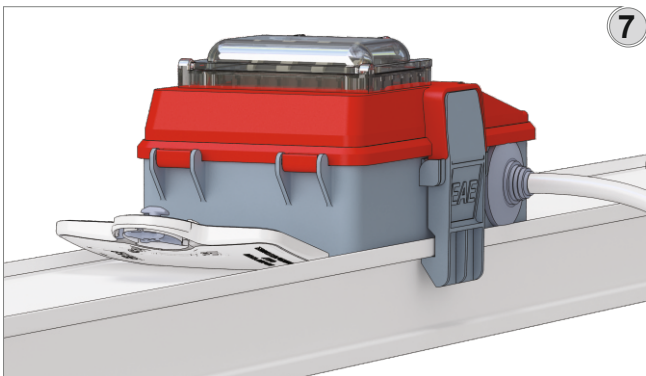

7

- Empty tap-off boxes are produced with MCB connection cables.
- When the tap-off boxes are used as single phase, the switch will be connected to one of the phase cables. Remaining phase cables should be insulated by using cable terminals for your safety.
- In order to balance phases of busbar, connected loads to the tap off boxes should be calculated carefully.

CE DECLARATION OF CONFORMITY

Product Group E-Line MK Busbar Energy Distribution System

Manufacturer EAE Elektrik Asansor End. Insaat San. ve Tic. A.S.
Akcaburgaz Mahallesi, 3114. Sokak,
No:10 34522 Esenyurt-Istanbul

The objects of the declaration described below is in conformity with the relevant Union harmonisation legislation. This declaration of conformity is issued under the sole responsibility of the manufacturer.

Standard :**EN 61439-6**

Low-voltage switchgear and controlgear assemblies - Part 6: Busbar trunking systems

IEC 61439-6

Low-voltage switchgear and controlgear assemblies - Part 6: Busbar trunking systems (busways)

CE - Directive

2014/35/EU "The Low Voltage Directive"

2014/30/EU "Electromagnetic Compatibility (EMC) Directive"

2011/65/EU "Restriction of the use of certain hazardous substances (RoHS)"

Technical Document Preparation Official:

EAE Elektrik Asansor End. Insaat San. ve Tic. A.S.
Akcaburgaz Mahallesi, 3114. Sokak, No:10 34522 Esenyurt-Istanbul

Emre GÜRLEYEN

Date

20.04.2016

Document Authorized Signatory

Elif Gamze KAYA OK
Deputy General Manager



PRODUCT OVERVIEW

(100...225A MK)

- 1- It is imperative that the busbar system be in a nominal current range of 100, 160, 225A Al or 160, 225A Cu.
- 2- The busbar system shall conform to the following phase configuration.
 - a- 4 conductors L1 / L2 / L3 / N / PE(Housing)
 - b- 5 conductors L1 / L2 / L3 / N / PE+Housing
 - c- 5 conductors (with clean earth) L1 / L2 / L3 / N / CPE / PE(Housing)
- 3- The insulation voltage of the busbar shall be 690V.
- 4- The busbar housing shall be of 0,50mm thick epoxy painted galvanized sheet metal. (RAL 7038)
- 5- The Al conductors shall be plated with nickel and then with tin, the Cu conductors shall be plated only with tin. The plating shall be continuous along the conductor.
- 6- The busbar joint shall have a single bolt construction and the nut of main joint bolt shall be a double headed nut, tightened at 20Nm.
- 7- The busbar housing shall be continuously clamped together by roll forming method.
- 8- 10 plug-in windows shall be located on a standard 3m length.
- 9- Busbar and tap off boxes shall be IP55 protection class under normal operation conditions.
- 10- IP protection covers of plug-in points shall be hinged and lockable from single point.
- 11- Tap off boxes up to 16A shall be removed from the busbar before opening their lids.
- 12- The tap off boxes above 16A, shall have the following mechanical and electrical safety features.
 - a- The box shall only be plugged in and removed from the busbar at "OFF" position.
 - b- The energy on the connected load shall be automatically cut, when the box lid is open.
 - c- The tap off box shall comply IP2X requirements, while it is plugged into the busbar and the lid is open.
- 13- All tap off box contacts shall be silver plated.
- 14- Jawed tap off box contacts shall be reinforced by steel springs.
- 15- Busbar systems shall be tested and certified according to IEC 61439-6 by international laboratories.
- 16- Busbar system shall have flexible elbows and expansion units.
- 17- Manufacturing facility of busbar systems shall have ISO 9001 and ISO 14001 certification.



CERIFICATE

EAE Elektrik Asan: Insaat San. ve Tic. A.Ş.
Akçaburgaz Mahallesi 119, Sokak No: 10
34510 Esenyurt / İstanbul
Turkey

Low-voltage busbar

EAE

MKA 16

Inc 160 A at 50 Hz,
For more details see

EAE Elektrik Asan: Insaat San. ve Tic.
Akçaburgaz Mahallesi 119, Sokak No: 10
34510 Esenyurt / İstanbul
Turkey

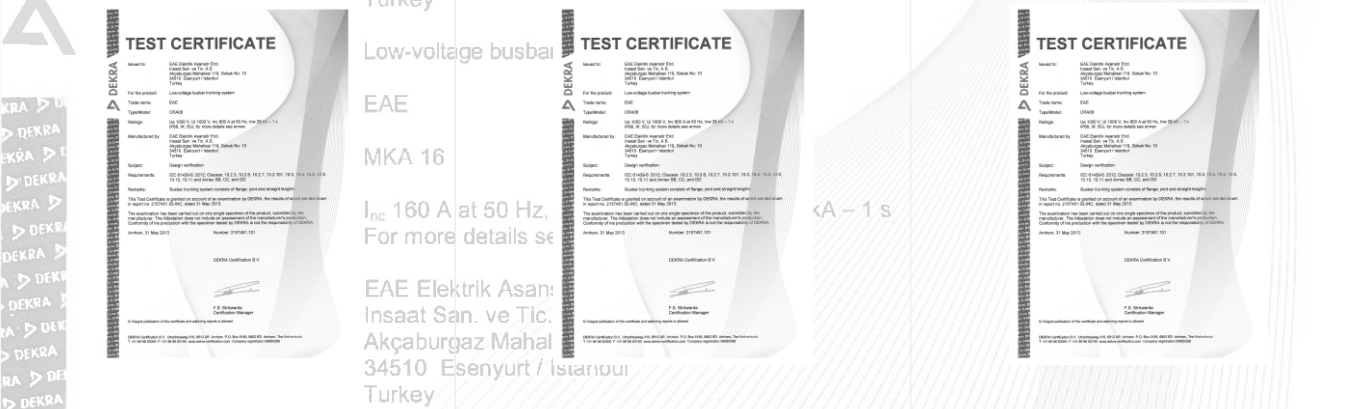

Subject:

Design verification

IEC 61439-6: 2012
Clauses: 10.2, 10.3, 10.4,
Annex BB, CC, and DD

Busbar trunking system

IEC 61439-6: 2012
Clauses: 10.2, 10.3, 10.4,
Annex BB, CC, and DD

Design verification

IEC 61439-6: 2012
Clauses: 10.2, 10.3, 10.4,
Annex BB, CC, and DD

Design verification

Design verification

Design verification

Design verification

Design verification

Design verification



Anhem, 4 May 2015

Number: 2172262.101



Design verification

Design verification

Design verification

Meander 1051, 6825 MJ, Anhem, The Netherlands

T +31 88 96 83000 F +31 88 96 83100 www.dekra-certification.com Company registration 09085396

Component List	Item	Component	Quantity
Prepared by			
Company :			
Project :			
Project No :			
Name :			
Date :			
Signature :			



Please duplicate this page for your own use.

Component List	Item	Component	Quantity
<p>Company : Project : Project No : Name : Date : Signature : Prepared by</p>			



Please duplicate this page for your own use.

Component List	Item	Component	Quantity
<p>Company : Project : Project No : Name : Date : Signature :</p> <p>Prepared by</p>			



Please duplicate this page for your own use.

PRODUCT TYPES



BUSBAR ENERGY DISTRIBUTION SYSTEMS



CABLE TRAYS



TROLLEY BUSBAR ENERGY DISTRIBUTION SYSTEMS



INDOOR SOLUTIONS



SUPPORT SYSTEMS

Please visit our website for the updated version of our catalogues.
www.eaelectric.com



EAE Elektrik A.S.
Head Office
Akcaburgaz Mahallesi,
3114. Sokak, No:10 34522
Esenyurt - Istanbul - TURKEY
Tel: +90 (212) 866 20 00
Fax: +90 (212) 886 24 20

EAE DL 3 Factory
Busbar
Makine Ihtisas Organize Sanayi
Bolgesi Mahallesi, 6. Cadde,
8. Sokak, No:6 41455
Dilovası - Kocaeli - TURKEY
Tel: +90 (262) 502 05 65
Fax: +90 (262) 502 05 70

Please visit our website for the updated version of our catalogues.
www.eaeelectric.com



IEC 61439-6



Catalogue 05-Eng. / Rev 14 00 pcs. 02/03/2023
D.S.

EAE has full right to make any revisions or changes on this catalogue without any prior notice.

